

Revision history			
Rev.	Date	Description	AUTHOR
1	27-2-2014	Drawing changed according to customer wishes	Gyula
2	28-2-2014	Added new view of flat band, to the data worm length	Gyula
3	26-3-2014	Drawing check and released	Gyula
4	15-4-2014	Clamping range changed to have a maximum stretched length of 2655 mm.	Gyula
5	16-4-2014	Clamping range changed to 830-845m according to customer wish. Drawing design changed to customer wish.	Gyula
6	5-6-2014	Product mark added	Gyula

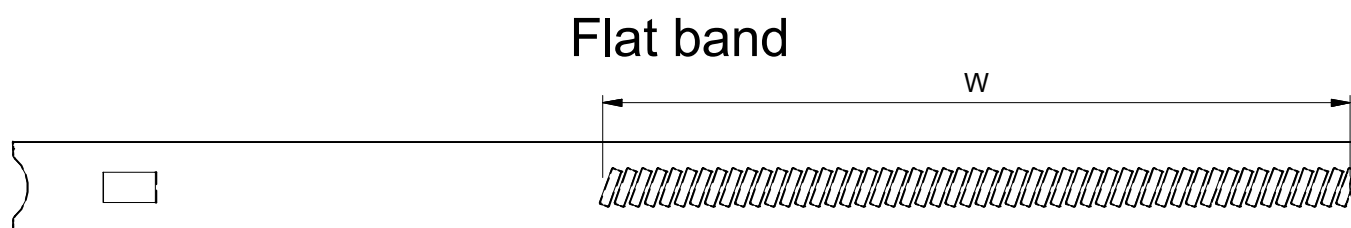
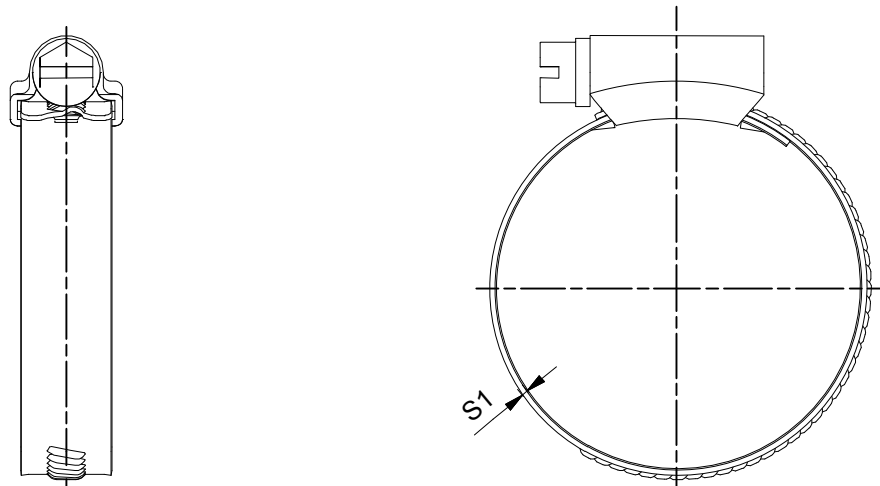

Flat band

Product mark:
MPC 830-845 W1

Hose clamp DIN 3017 - A -830-845 X12- W1 - 2

Description	-	Data
Band thickness	S1	0.5-1.0 mm
Tightening torque	AD*	max. 5 Nm
Breaking torque	PD**	6.5 Nm
Free torque		max 2 Nm
Worm length	W	120
AD*= Maximum advised torque		
PD**=Minimum test torque in Nm according to DIN 3017-1.		

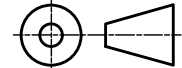
		© 2013 MPC INDUSTRIES BV, developed and designed by MPC INDUSTRIES BV	
		General Tolerances: according to: DIN 2768-vL	
<small>NOTICE TO PERSONS RECEIVING THIS DRAWING AND/OR TECHNICAL INFORMATION: MPC Industries BV claims proprietary rights to the material disclosed hereon. This drawing and/or technical information is issued in confidence for engineering information only and may not be reproduced or used to manufacture anything shown or referred to hereon without direct written permission from MPC Industries BV to the user. This drawing and/or technical information is the property of MPC Industries BV and is loaned for mutual assistance to be returned when its purpose has been served. THIS DRAWING AND/OR TECHNICAL INFORMATION IS THE PROPERTY OF MPC INDUSTRIES BV. DO NOT SCALE FROM DRAWING.</small>		SURFACE TREATMENT AND OR PROTECTION:	
		Material:	
Doc no.: ST830.dwg		Part number: ST 830	
Third angle projection: 		Description: MPC Industries, ST worm drive clamp 830-845 mm	
Drawn by: Gyula	Creation date: 20-11-2013	Revision: 6	
Checked by: Gyula K.	Checked date: 26-3-2014	Format: A3	
Scale 1:5	Units: mm		
Status: Released			
MPC Industries B. V. Badweg 38 8401 BL Gorredijk Postbus 225 8400 AE Gorredijk. Tel.: . 0513 465477 Fax.: 0513 465736			

Material code	Hexagon head screw	Wormdrive housing	Band
W1	Steel (according to the choice of the manufacturer)	Steel (according to the choice of the manufacturer)	Steel with minimum tensile strength of 400N/mm2, AISI 430 or higher