

Top view (1 : 2)

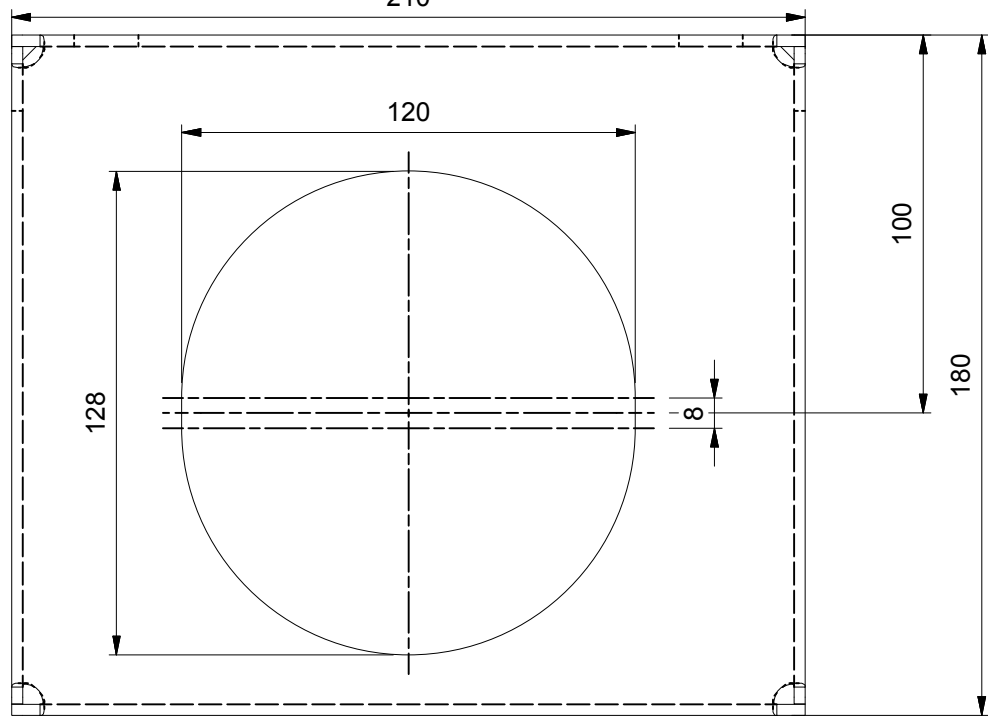

Front view (1 : 2)

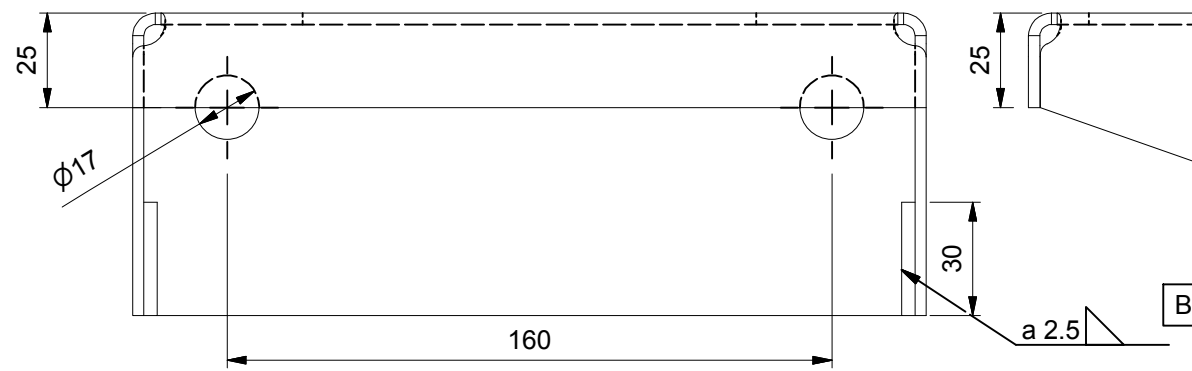

Side view (1 : 2)

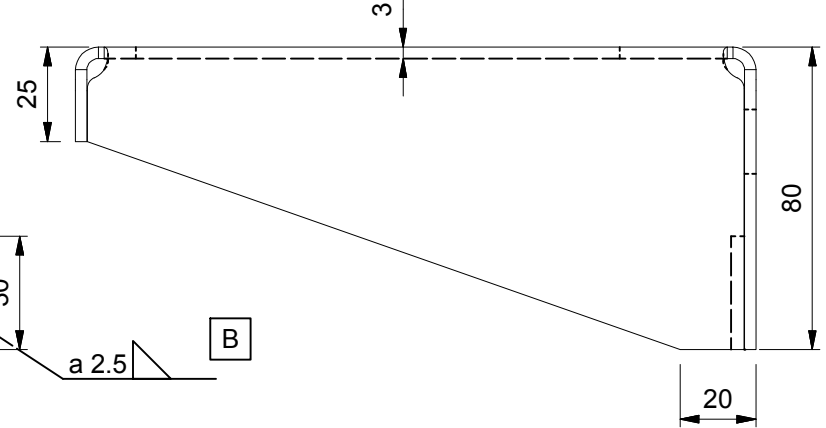

Iso view (1 : 2) A (1 : 1)

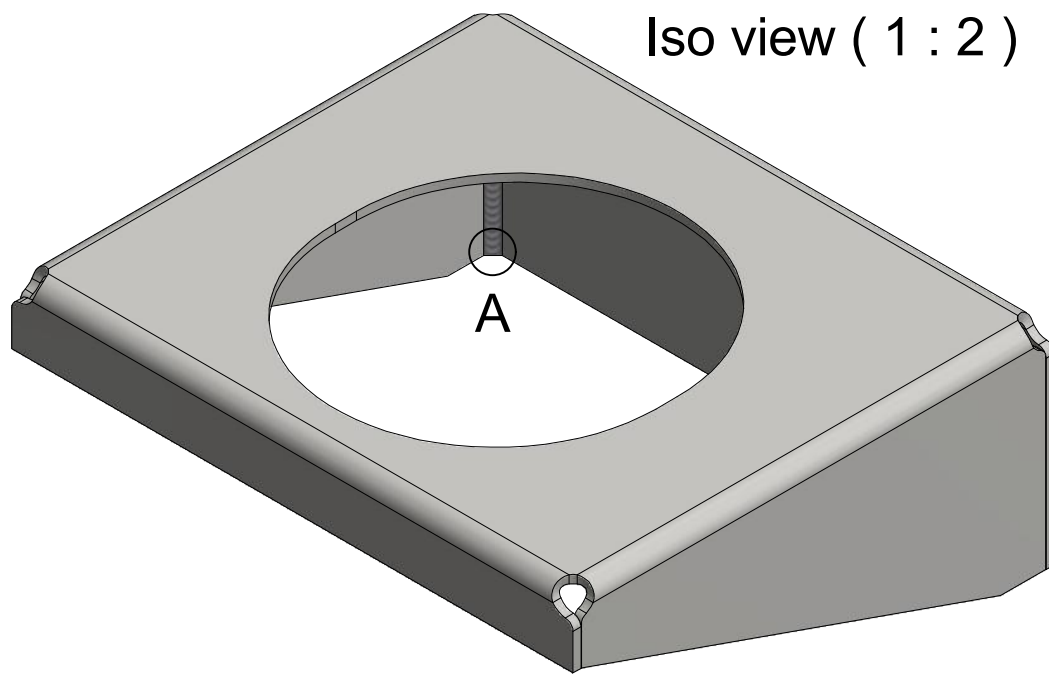

Flat pattern (1 : 3)

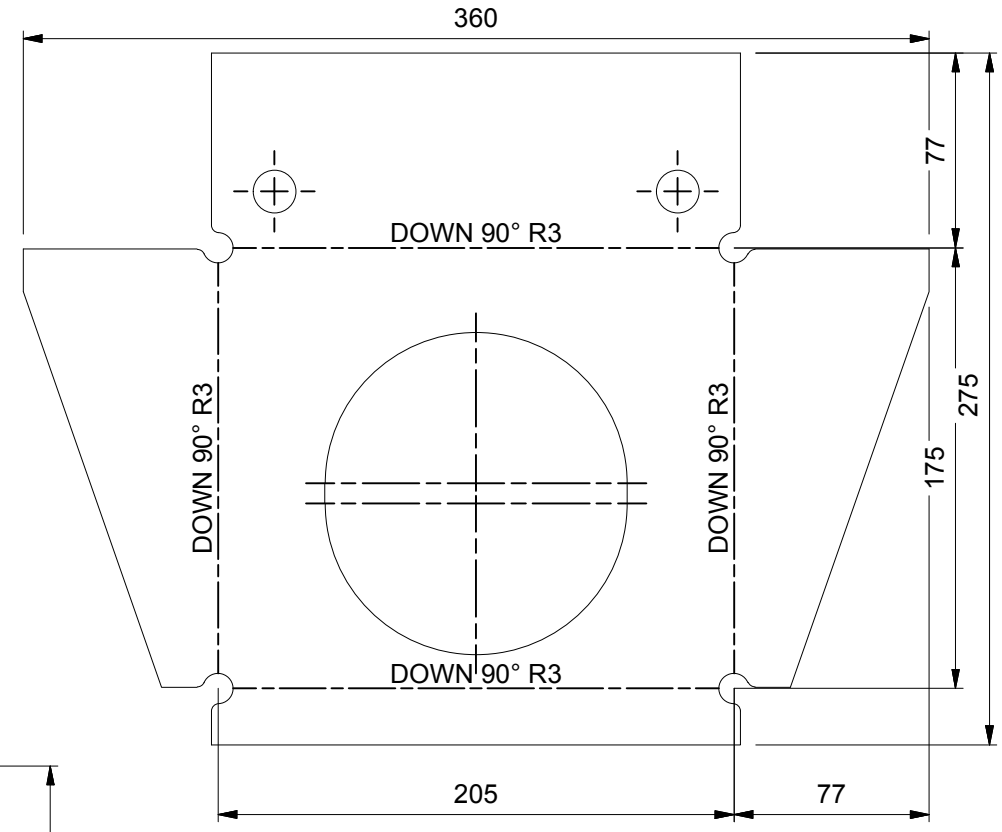

Revision history			
Rev.	Date	Description	DESIGNER
A	19-9-2017	Checked drawing and set as "released"	M. Wiersma
B	6-10-2017	Changed weld, and its annotation	M. Wiersma

© 2017 MPC INDUSTRIES BV, developed and designed by MPC INDUSTRIES BV

General Tolerances: according to: DIN 2768-vL

MPC INDUSTRIES

SURFACE TREATMENT AND OR PROTECTION: FE/Z/12/A According to DIN 50961

NOTICE TO PERSONS RECEIVING THIS DRAWING AND/OR TECHNICAL INFORMATION:
 MPC Industries BV claims proprietary rights to the material disclosed hereon. This drawing and/or technical information is issued in confidence for engineering information only and may not be reproduced or used to manufacture anything shown or referred to hereon without direct written permission from MPC Industries BV to the user. This drawing and/or technical information is the property of MPC Industries BV and is loaned for mutual assistance to be returned when its purpose has been served.
 THIS DRAWING AND/OR TECHNICAL INFORMATION IS THE PROPERTY OF MPC INDUSTRIES BV

DO NOT SCALE FROM DRAWING.

Material: S235JR Mass: 1,463 kg

Doc no.: B-1M.dwg

Third angle projection:

Part number: **B-1M**

Drawn by: Gy.Kardos	Creation date: 17-3-2017	Description: MPC Industries, Suport Bracket B-1M	Revision: B
Checked by: M. Wiersma	Checked date: 19-9-2017		
Scale 1:2	Units: mm	Format: A3	
Status: Released			