

Front view ( 1 : 3 )

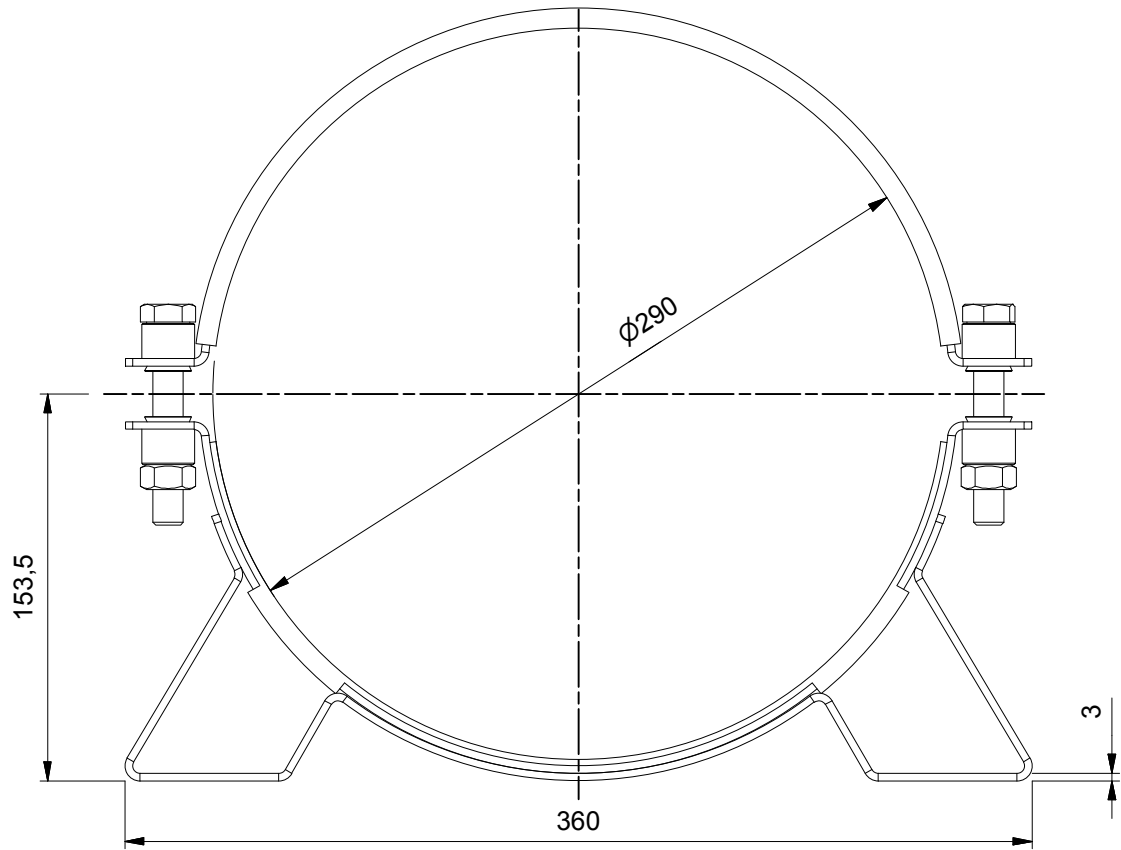

Side view ( 1 : 3 )

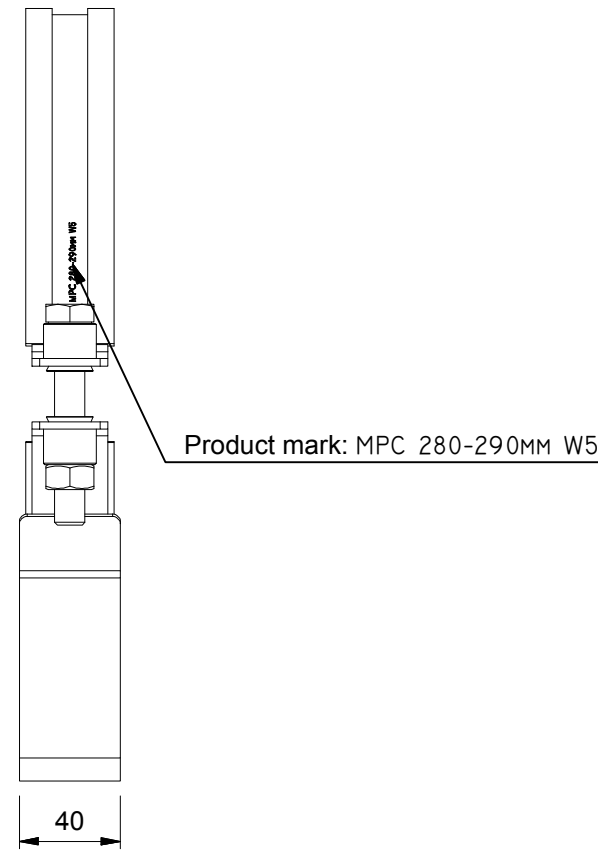

Parts identification ( 1 : 3 )

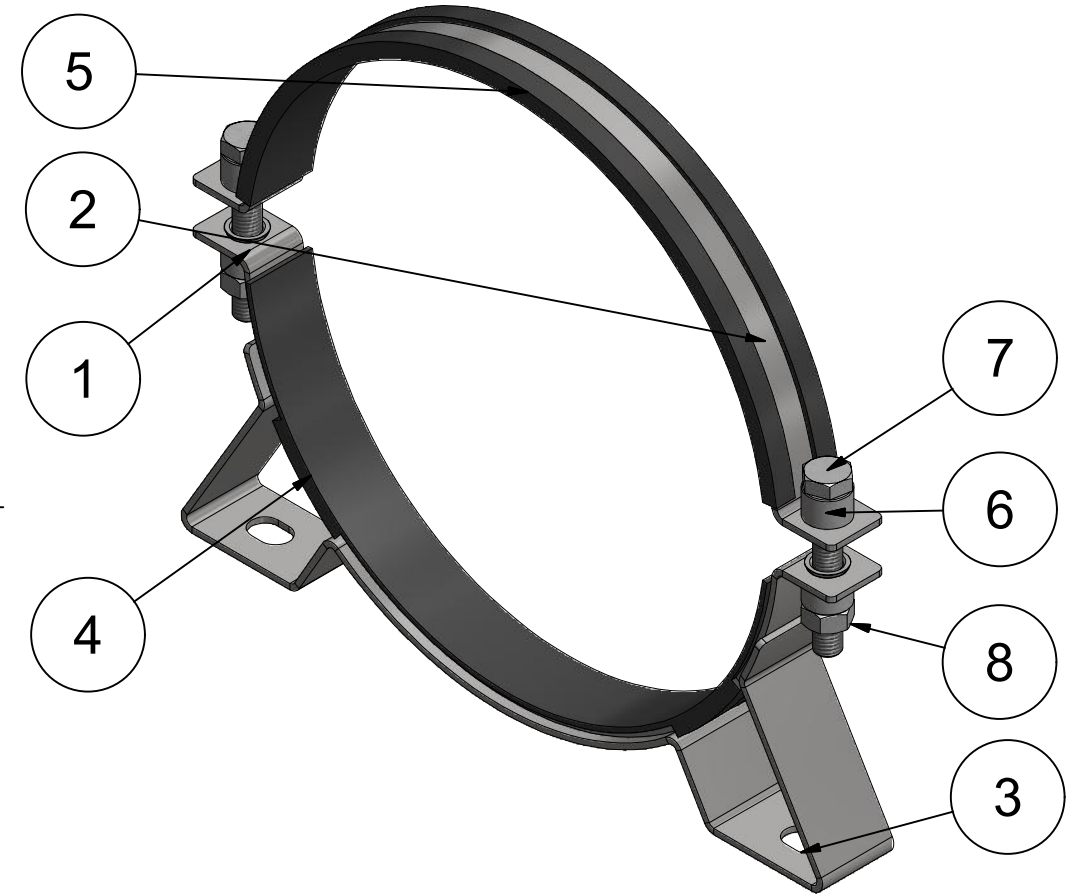

Bottom view ( 1 : 3 )

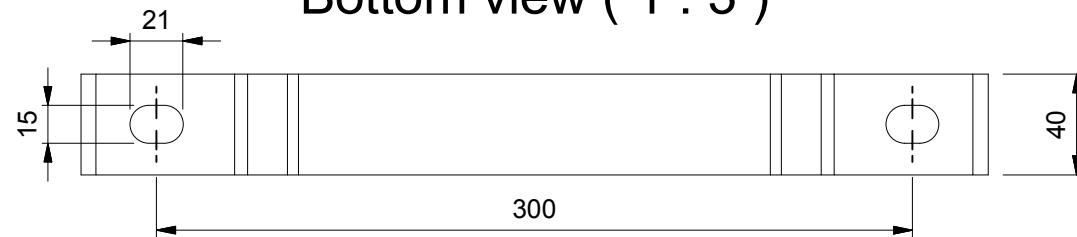

Item	Qty	Description	Material
1	1	Lower clamp part	Stainless Steel AISI 316
2	1	Upper clamp part	Stainless Steel AISI 316
3	1	Console part	AISI316
4	1	Lower rubber part	EPDM Rubber Shore hardness 65°±5°
5	1	Upper rubber part	EPDM Rubber Shore hardness 65°±5°
6	4	Rivet Ø21	AISI316
7	2	Srew M12x80	RVS A4-80
8	2	Hex Nut M12	RVS A4-80



© 2013 MPC INDUSTRIES BV, developed and designed by MPC INDUSTRIES BV

General Tolerances: according to: DIN 2768-vL

SURFACE TREATMENT AND/OR PROTECTION:

NOTICE TO PERSONS RECEIVING THIS DRAWING AND/OR TECHNICAL INFORMATION:

MPC Industries BV claims proprietary rights to the material disclosed hereon. This drawing and/or technical information is issued in confidence for engineering information only and may not be reproduced or used to manufacture anything shown or referred to hereon without direct written permission from MPC Industries BV to the user. This drawing and/or technical information is the property of MPC Industries BV and is loaned for mutual assistance to be returned when its purpose has been served. THIS DRAWING AND/OR TECHNICAL INFORMATION IS THE PROPERTY OF MPC INDUSTRIES BV.

DO NOT SCALE FROM DRAWING.

Material:

Dimensions:

Doc no.: ACCUT4W5280290.dwg

Third angle projection:

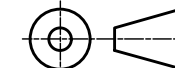

Part number:

**ACCUT4W5280290**

Drawn by: Gy.Kardos

Creation date: 02/09/2015

Checked by:

Checked date:

Scale 1:3

Units: mm

Status: Released

Description:  
MPC Industries, Accumulator  
clamp type 4, 280-290 mm, W5

Revision:

Format:

**A3**