

Front view (1 : 2)

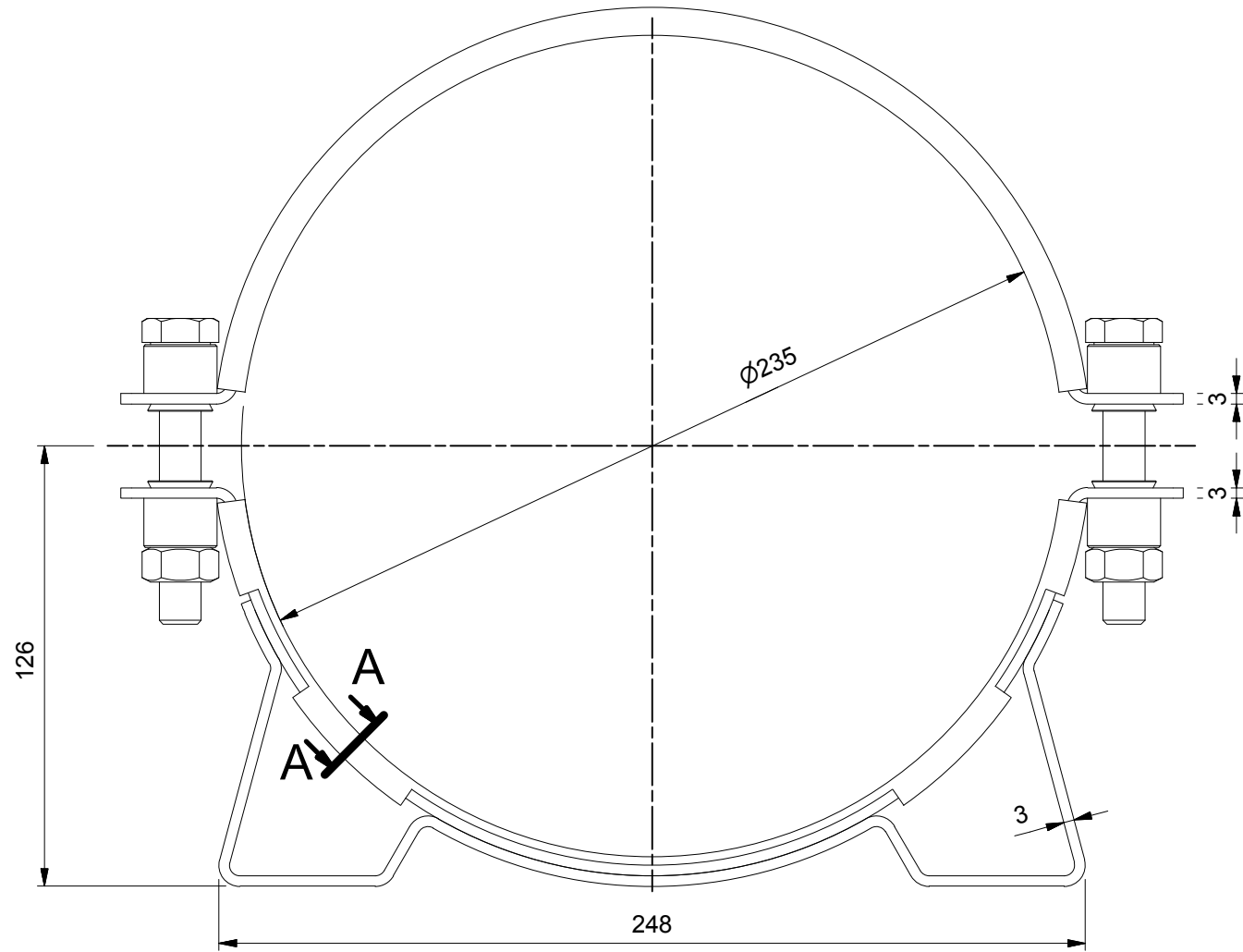

Side view (1 : 2)

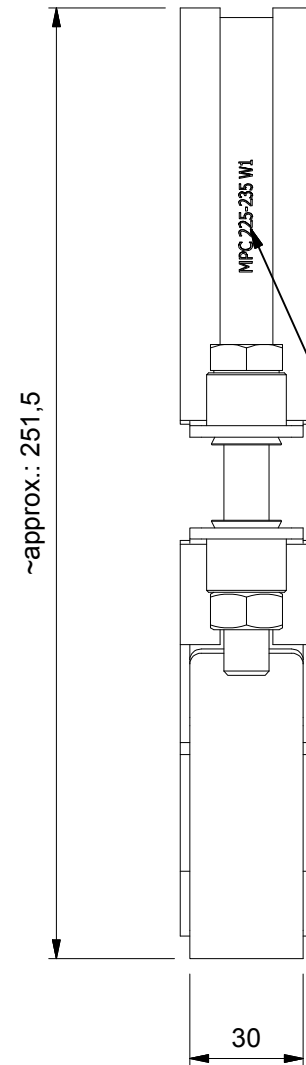

Parts identification (1 : 3)

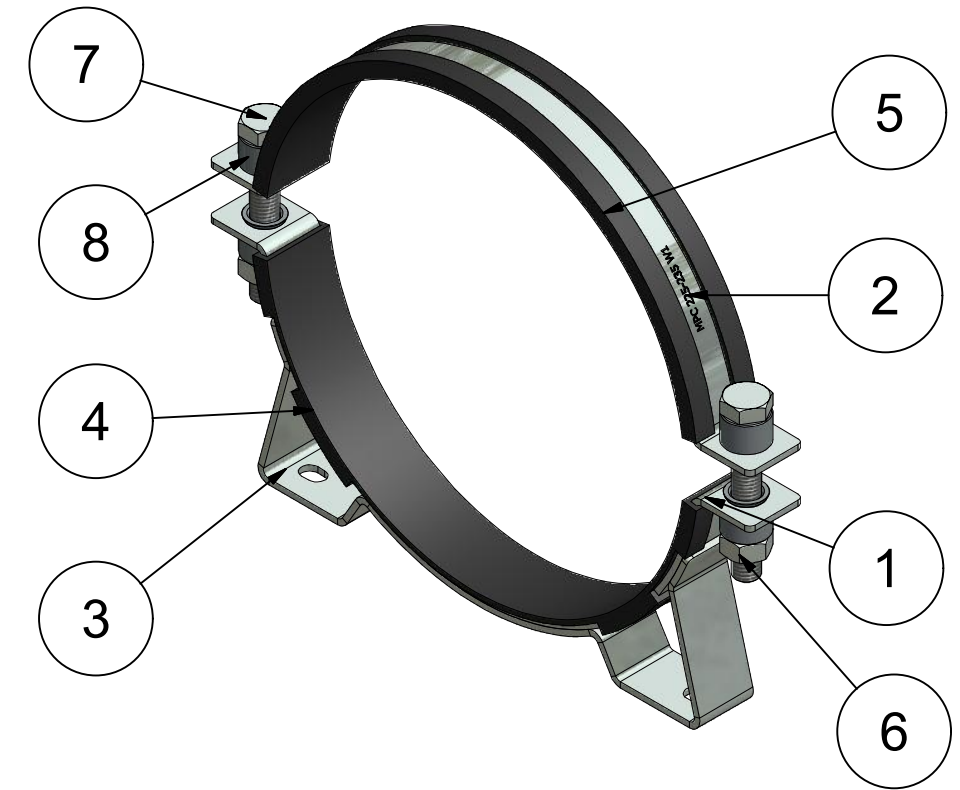

Production marking

Item	Qty	Description	Material
1	1	Lower clamp part	Zinc plated, Steel, Mild
2	1	Upper clamp part	Zinc plated, Steel, Mild
3	1	Console part	Zinc plated, Steel, Mild
4	1	Lower rubber part	EPDM Rubber Shore hardness 65°±5°
5	1	Upper rubber part	EPDM Rubber Shore hardness 65°±5°
6	2	NUT M12, DIN 934	Zinc plated, ST 8.8
7	2	Screw DIN 933 M12*80 full threaded	Zinc plated, ST 8.8
8	4	Rivet Ø21	Zinc plated, Steel, Mild

Bottom view (1 : 2)

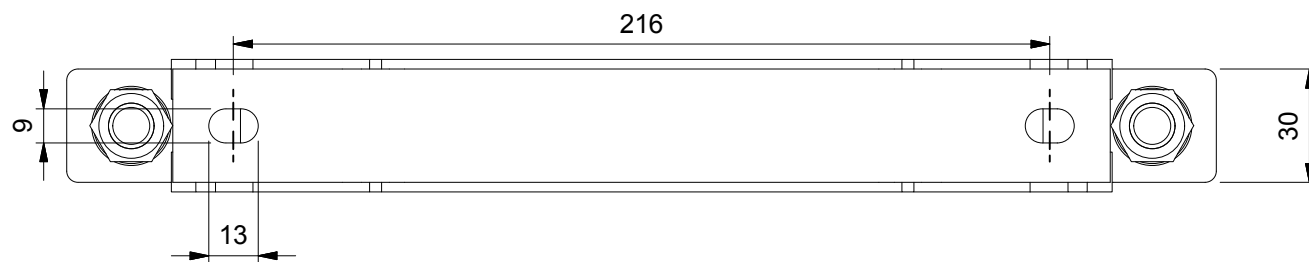

A-A (1 : 2)

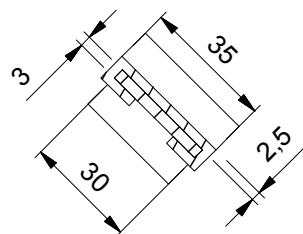

Product mark: MPC 225-235 W1

Revision history			
Rev.	Date	Description	AUTHOR
-	19-4-2013	Drawing created	gyula
1	6-1-2014	Drawing renewed	gyula



Material:	Dimensions: -
Doc no.: ACCU1225.dwg	Part number: ACCU1225
Third angle projection:	Description: MPC Industries Accumulator clamp, 225-235mm, W1

Drawn by: gyula	Creation date: 19-4-2013	Revision: 1
Checked by:	Checked date:	
Scale: 1:2	Units: mm	Format: A3
Status: Released		

NOTICE TO PERSONS RECEIVING THIS DRAWING AND/OR TECHNICAL INFORMATION:
MPC Industries BV claims proprietary rights to the material disclosed hereon. This drawing and/or technical information is issued in confidence for engineering information only and may not be reproduced or used to manufacture anything shown or referred to hereon without direct written permission from MPC Industries BV to the user. This drawing and/or technical information is the property of MPC Industries BV and is loaned for mutual assistance to be returned when its purpose has been served.
THIS DRAWING AND/OR TECHNICAL INFORMATION IS THE PROPERTY OF MPC INDUSTRIES BV