

MPC TYPE "GS"

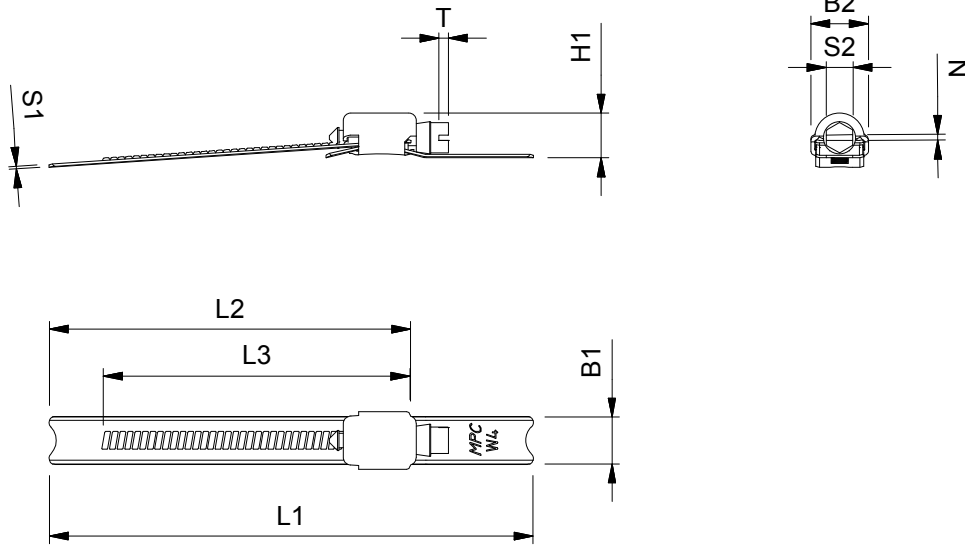
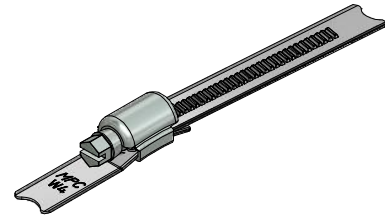

Revision history

Rev.	Date	Description	AUTHOR
1	13/5/2015	Sizes changed according to production (bandwidth)	Gyula
2	23/12/2015	Data tabel reviewed and clamps name added	Gyula

Sizes

Clamp Name	Band width	Band thickness	Total length L1	length min. max.	Clamp band L2	Worm length L3	Wormdrive B2 max.	Housing H1 max.	Hexagon N	head S2	srew T	Tightening Torque AD	Breaking Torque PD
GS9	9	0,75	60	75	50	35	12,5	14	1,2	6	2	3 Nm	4 Nm
GS49	9,7	0,75	85	90	65	50	12,5	14	1,2	6	2	3 Nm	4 Nm
GS12	12,7	0,75	109	113	84.5	70	16	14	1,2	6	2	3 Nm	4 Nm

AD*= Maximum advised torque.

PD**=Minimum test torque in Nm according to DIN 3017-1.

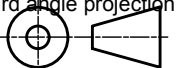
	Material:	W4		Part number:	GS clamp		Revision:
	Third angle projection:	Description:		MPC Industries GS Clamp		1	
Drawn by: Gyula	Creation date: 05/03/2014			Format:	A4		
Scale 1:1	Units: mm						